



Owner's Operation and Maintenance Manual

Eclipse Manual Wheelchair

DEALER: This manual must be given to the user of the wheelchair

USER: Before using this wheelchair, read this entire manual and
save for future reference



For more information regarding PDG products,
parts & service, please visit www.pdgmobility.com

US Patent # 5,957,474



Class 1 Medical Device
Registration CA 004986

March 2008

WARNING

Do not operate this equipment without first reading and understanding this manual. If you are unable to understand the warnings and instructions, contact a health care professional such as a Doctor or Therapist who is familiar with this type of product before attempting to use this equipment. Otherwise, injury or damage may result.

Refer to this manual regularly for maximum safety and performance.

TABLE OF CONTENTS

Table of Contents	2	Operation & Safety	8
Special Notes	2	Removable Arms	8
Safety Summary	2	Wheel Locks	8
Safety Handling of Wheelchairs	3	Adjustable Back Frame	8
Wheelchair Terminology	6	Upholstery	8
Packaging	6	Front Rigging	8
Out-of-the-box Assembly	6	Rear Wheels	9
Safety Inspection Checklist	7	Fine tuning... Adjustment Guide	9
Troubleshooting	7	Disclosures and Warranty	11
Maintenance	7		

SPECIAL NOTES

WARNING/CAUTION notices as used in this manual apply to hazards or unsafe practices which could result in personal injury or property damage.

NOTICE THE INFORMATION CONTAINED IN THIS DOCUMENT IS SUBJECT TO CHANGE WITHOUT NOTICE.

WHEELCHAIR USER

As a manufacturer of wheelchairs, PDG endeavors to supply wheelchairs to meet many needs of the end user. However, final selection of the type of wheelchair to be used by an individual rests solely with the user and his/her health care professional capable of making such a selection.

WHEELCHAIR TIE-DOWN RESTRAINTS AND SEAT RESTRAINTS

PDG recommends that wheelchair users NOT be transported in vehicles of any kind while in wheelchairs. If transportation in a vehicle while in the wheelchair is required, the wheelchair must be equipped with PDG factory installed Transport-Ready Tie-down mounting points. The wheelchair must be restrained from movement using a government approved wheelchair tie-down system and the vehicle must be equipped with government approved anchor points.

Users of wheelchairs should be transferred into appropriate seating in vehicles for transportation and use be made of the restraints made available by the auto industry. PDG can not and does not recommend wheelchair transportation systems.

REGARDING RESTRAINTS - SEAT BELTS - IT IS THE OBLIGATION OF THE HME DEALER, THERAPISTS AND OTHER HEALTH CARE PROFESSIONALS TO DETERMINE IF A SEATING RESTRAINT IS REQUIRED TO ENSURE THE SAFE OPERATION OF THIS EQUIPMENT BY THE USER. SERIOUS INJURY CAN OCCUR IN THE EVENT OF A FALL FROM A WHEELCHAIR.

SAFETY SUMMARY

OPERATING INFORMATION

WARNING

To determine and establish particular safety limits, practice bending, reaching and transferring activities in several combinations in the presence of a qualified health professional BEFORE attempting active use of the wheelchair.

DO NOT attempt to reach objects if you have to move forward in the seat.

DO NOT attempt to reach objects if you have to pick them up from the floor by reaching down between your knees.

DO NOT lean over the top of the back upholstery to reach objects from behind. This may cause the wheelchair to tip over.

DO NOT shift your weight or sitting position toward the direction you are reaching as the wheelchair may tip over.

DO NOT use an escalator to move a wheelchair between floors. Serious bodily injury may occur.

DO NOT attempt to stop a moving wheelchair with the wheel locks. WHEEL LOCKS ARE NOT BRAKES.

Before attempting to transfer in or out of the wheelchair, every precaution should be taken to reduce the gap distance. Turn both casters toward the object you are transferring onto. When transferring to and from the wheelchair, ALWAYS ENGAGE BOTH WHEEL LOCKS.

DO NOT climb, go up or down ramps or traverse slopes greater than 9°.

DO NOT attempt to move up or down an incline with a water, ice or oil film.

DO NOT attempt to ride over curbs or obstacles. Doing so may cause your wheelchair to turn over and cause bodily harm or damage to the wheelchair.

DO NOT use unauthorized parts, accessories, or adapters other than those authorized by PDG.

DO NOT attempt to lift wheelchair by any removable (detachable) parts.

For products supplied with anti-tippers, anti-tippers must be attached at all times.

Do not use the footplate as a platform when getting in or out of the wheelchair.

DO NOT tilt the wheelchair without assistance.

DO NOT operate on roads/streets/highways.

ALWAYS wear your seat restraint.

DO NOT stand on frame of the wheelchair.

TIRE PRESSURE

If pneumatic tires are supplied, DO NOT use your wheelchair unless it has the proper tire pressure (p.s.i.). DO NOT over inflate the tires. Failure to follow these suggestions may cause the tire to explode and cause bodily harm.

Replacement of a pneumatic tire or tube MUST be performed by an authorized PDG Dealer or Qualified Technician.

WEIGHT TRAINING

PDG DOES NOT recommend the use of its wheelchairs as a weight training apparatus. PDG wheelchairs have NOT been designed or tested as a seat for any kind of weight training. If occupant uses said wheelchair as a weight training apparatus, PDG shall NOT be liable for bodily injury and the warranty will be voided immediately.

WEIGHT LIMITS (Eclipse 350 max wt = 350 lb / 159 KG) (Eclipse 600 max wt = 600 lb / 272 KG, may upgrad to 1000 lb / 453 KG)

Maximum user weight is shown on the product order form. The Manufacturer has designed the ECLIPSE Series manual wheelchair for use with individuals weighing 250 pounds and more. It is important to note that the activity level of individual wheelchair users must be considered when selecting an appropriate product. For example, a 270 lb. active wheelchair user could subject the wheelchair to more stress than a 350 LB passive user. The Manufacturer recommends that very active heavy duty users consider the use of extra heavy-duty construction.

METHOD 1 - WHEELCHAIR WITH STEP TUBES

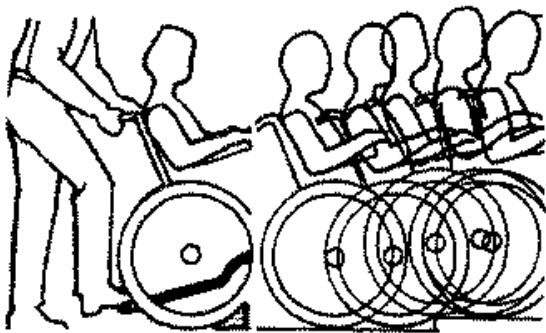

WHEELCHAIR WITH STEP TUBES

Apply a continuous downward motion until the balance point is achieved and the front casters clear the curb. At this point, the assistant will feel a difference in the weight distribution.

Roll the wheelchair forward and slowly lower the wheelchair in one continuous movement. Do not let the wheelchair drop the last few inches to the ground. This could result in injury to the occupant. Push the wheelchair forward until the rear wheels roll up and over the curb.

METHOD 2 - WHEELCHAIRS WITHOUT STEP TUBES

Unless the first assistant has exceptional upper body strength, it is recommended that METHOD 2 use two (2) assistants. The second assistant should be positioned at the front of the wheelchair lifting upward on a non-removable (non-detachable) part of the wheelchair frame when lifting

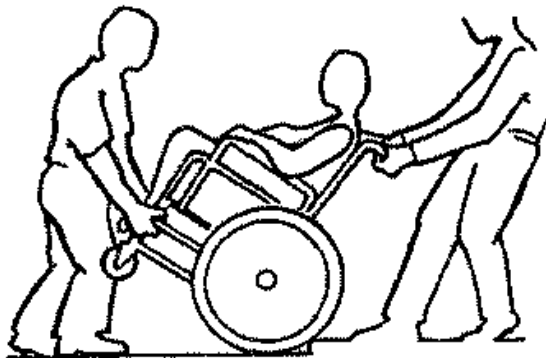

WHEELCHAIR WITHOUT STEP TUBE

the wheelchair and stabilizing the wheelchair when the wheelchair is being lowered to the ground.

The first assistant should stand on the sidewalk and turn the wheelchair so that the rear wheels are against the curb. The wheelchair should be tilted back to the balance point and, in one continuous downward movement, the rear wheels should be pulled up and over the curb. DO NOT return the front casters to the ground until the wheelchair has been pulled backward far enough for the front casters to clear the edge of the curb.

STAIRWAYS

WARNING: Do not attempt to lift a wheelchair by lifting on any removable (detachable) parts. Lifting by means of any removable (detachable) parts of a wheelchair may result in injury to the user or damage to the wheelchair.

Extreme caution is advised when it is necessary to move an occupied wheelchair up or down the stairs. PDG recommends using two (2) assistants and making thorough preparations. Make sure to use ONLY secure, non-detachable parts for hand-held supports

Follow this procedure for moving the wheelchair between floors when an elevator is NOT available:

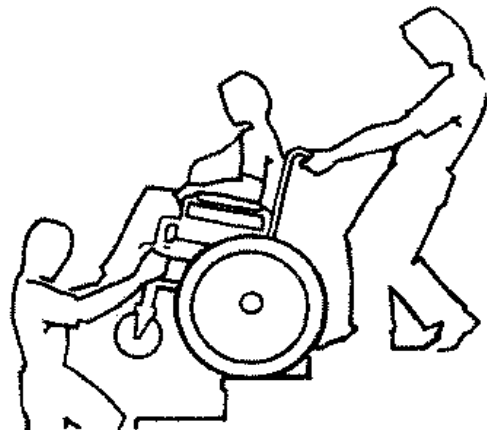

from the stairway.

1. After the wheelchair has been tilted back to the balance point, one assistant (in the rear) backs the wheelchair up against the first step, while securely grasping a non-removable (non-detachable) part of the wheelchair for leverage.

2. The second assistant, with a firm hold on a non-detachable part of the framework, lifts the wheelchair up and over the stair and steadies the wheelchair as the first assistant places one (1) foot on the next stair and repeats STEP 1.

3. The wheelchair should not be lowered until the last stair has been negotiated and the wheelchair has been rolled away

ESCALATORS? SORRY!

DO NOT use an escalator to move a wheelchair between floors. Serious bodily injury may occur.

TRANSFERRING TO AND FROM OTHER SEATS



WARNING: BEFORE attempting to transfer in or out of the wheelchair, every precaution should be taken to reduce the gap distance. Turn both casters toward the object you are transferring onto. Also be certain the wheel locks are engaged to help prevent the wheels from moving.

CAUTION: When transferring, position yourself as far back as possible in the seat. This will prevent damaged upholstery and the possibility of the wheelchair tipping forward.

NOTE: This activity may be performed independently provided you have adequate mobility and upper body strength.

Position the wheelchair as close as possible along side the seat to which you are transferring, with the front casters pointing toward it. Engage wheel locks. Shift body weight into seat with transfer.

During independent transfer, little or no seat platform will be beneath you. Use a transfer board if at all possible.

PERCENTAGE OF WEIGHT DISTRIBUTION

WARNING: DO NOT attempt to reach objects if you have to move forward in the seat or pick them up from the floor by reaching down between your knees.

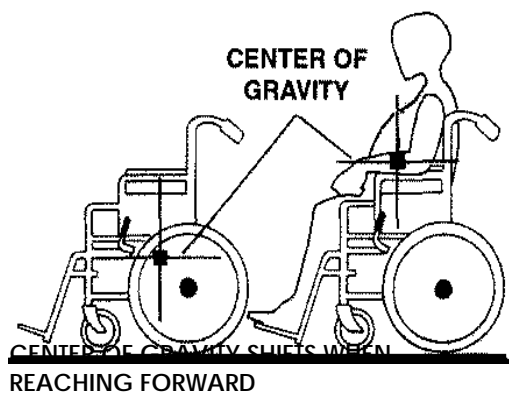

Many activities require the wheelchair owner to reach, bend and transfer in and out of the wheelchair. These movements will cause a change to the normal balance, the center of gravity, and the weight distribution of the wheelchair. To determine and establish your particular safety limits, practice bending, reaching and transferring activities in several combinations in the presence of a qualified health professional BEFORE attempting active use of the wheelchair.

Proper positioning is essential for your safety. When reaching, leaning, bending

forward, it is important to use the front casters as a tool to maintain stability and balance.

Wheelchair Terminology

1. Removable Arm
2. Armrest Pad
3. Arm Release
4. Footrest
5. Foot Plate
6. Caster
7. Wheel Lock
8. Rear Wheel
9. Handrim
10. Base Frame
11. Seat Frame
12. Backrest

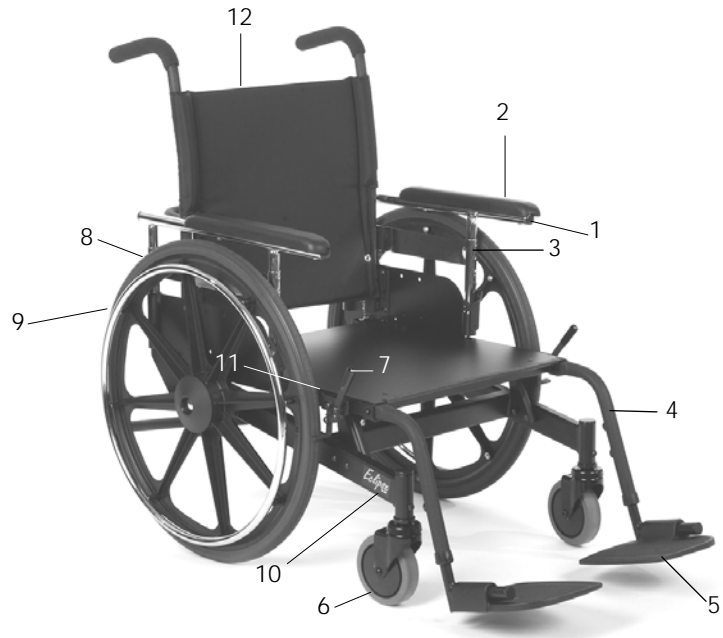

PACKAGING

UNPACKING

NOTE: Unless the PDG Eclipse is to be assembled immediately, retain cartons and packing materials for use in storing the wheelchair until assembly is required.

INSPECTION

OUT OF THE BOX ASSEMBLY INSTRUCTIONS

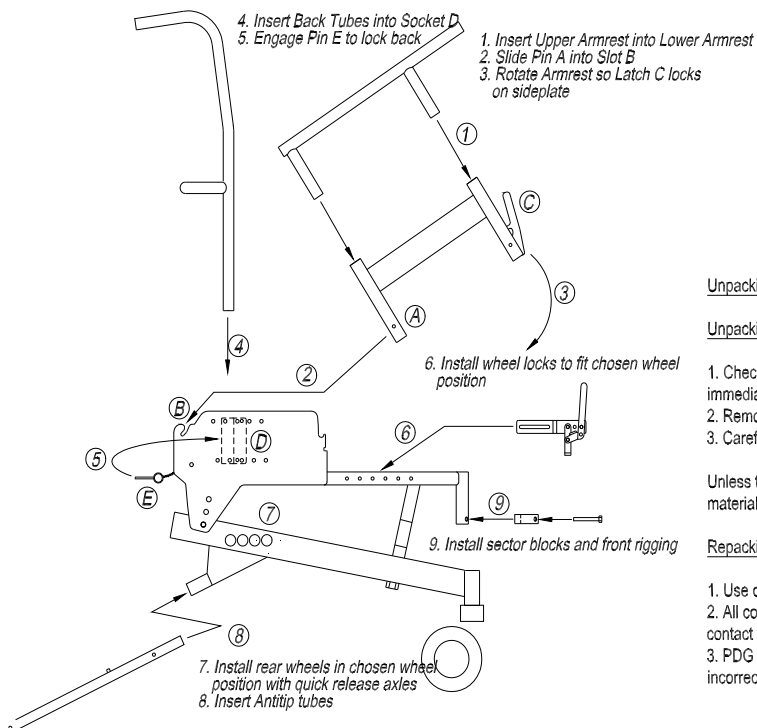

Your package should include the following components:

1. One Eclipse Frame
2. Two Rear Wheels
3. Two Quick Release Axles
4. Two Anti-tip Tubes
5. Two Armrest Assemblies
6. One Eclipse Back
7. One Pair Front Rigging (Optional)
8. Two Sector Blocks (Optional)

Unpacking and Repacking the Equipment

Unpacking

1. Check for any obvious damage to the carton or its contents. If damage is evident, notify PDG immediately.
2. Remove all loose packing from the carton.
3. Carefully Remove all components from the carton, inspecting them as you assemble the equipment.

Unless the PDG Eclipse is to be assembled and used immediately, retain cartons and packing materials for use in storing the wheelchair until assembly is required.

Repacking

1. Use original dividers and packing material to repackage the wheelchair.
2. All components must be packaged using corrugated panels to ensure no component comes in contact with any other component during shipping.
3. PDG will not be responsible for any damage caused as a result of components being repacked incorrectly.

1. Examine exterior of the PDG Eclipse for nicks, dents, scratches or other damages. Inspect all components. If damage is evident, notify your Dealer/Carrier.

STORAGE

1. Store the repackaged PDG Eclipse in a dry area.
2. DO NOT place other objects on top of the repackaged wheelchair.

SAFETY INSPECTION CHECKLIST

NOTE: Twice a year take your wheelchair to a qualified dealer for a thorough inspection and servicing. Regular cleaning will reveal loose or worn parts and enhance the smooth operation of your wheelchair. To operate properly and safely, your wheelchair must be cared for just like any other vehicle. Routine maintenance will extend the life and efficiency of your wheelchair. Initial adjustments should be made to suit your personal body structure and preference. Thereafter follow these maintenance procedures:

ITEM	INITIALLY	INSPECT/ ADJUST WEEKLY	INSPECT/ ADJUST MONTHLY	INSPECT/ ADJUST/ PERIODICALLY
GENERAL Wheelchair rolls straight (no excessive drag or pull to one side.	X			X
WHEEL LOCKS Do not interfere with tires rolling. Pivot points free of ware and looseness. Wheel locks easy to engage.	X X X		X X	X
SEAT/BACK UPHOLSTERY Inspect for rips or sagging. Inspect fastening to ensure they are secure.	X X		X	X
REAR WHEELS No excessive side movement or binding when lifted and spun. Quick-release axles lock properly.	X X	X		X
FRONT CASTER Inspect wheel/fork assembly for proper tension by spinning caster; caster should come to a gradual stop. Wheel bearings are clean and free of moisture. CAUTION: Wheels and tires should be checked periodically for cracks and wear, and should be replaced when necessary.	X X X	X	X X	
TIRES Inspect for flat spots and wear. If pneumatic tires, check for proper installation. CAUTION: Wheels and tires should be checked periodically for cracks and wear, and should be replaced when necessary.	X	X X		
CLEANING Clean upholstery and armrests.	X			X

TROUBLESHOOTING

CHAIR VEERS RIGHT	CHAIR VEERS LEFT	SLUGGISH TURN OR PERFORMANCE	CASTERS FLUTTER	SQUEAKS AND RATTLES	LOOSE-NESS IN CHAIR	CHAIR 3 WHEELS	SOLUTIONS
X	X	X	X			X	If pneumatic, check tires for correct/equal pressure.
		X	X	X	X		Check for loose stem nuts and bolts.
X	X	X	X				Check caster angle.
X	X		X				Check that both casters contact ground at the same time.

MAINTENANCE

MAINTENANCE - FINE TUNING THE FIT... ADJUSTMENT GUIDE

The following instructions are intended to provide assistance in making wheelchair adjustments. It is important to note the initial wheelchair configuration prior to making changes. When making changes, dealers and users should do so under the guidance of a health care professional who is knowledgeable of the particular limitation of the wheelchair user. Be sure that when finished, all components are properly tightened and have been completed in accordance with these instructions. **DO NOT** over tighten hardware when attaching to the frame as overtightening may cause damage to frame tubing.

Tools Required

Philips Screw Driver

Allen Keys: 1/8" 5/32", 3/16", 8 mm

Adjustable or Open End Wrench: 7/16", 1-1/4, 1-5/16"

Socket Head Driver with socket Heads: 9/16", 3/4", 1-1/4"

CLEANING

Periodic cleaning of all surfaces will help keep your wheelchair looking good and operating properly. All surfaces can be cleaned using warm water and a mild soap solution. Do not use abrasive cleaners on any surfaces.

SUGGESTED MAINTENANCE PROCEDURES

1. Before using your PDG Eclipse, make sure all nuts and bolts are tight. Check all parts for damage or wear and replace. Check all parts for proper adjustment.
2. If applicable, keep quick-release axles free of dirt and lint to ensure positive locking and proper operation. Refer to ADJUSTING THE QUICK-RELEASE AXLE or in PROCEDURE 4 of this manual.
3. If applicable, oil quick-release axles at least once (1) a month (3-in-1 oil or equivalent).

WARNING: If pneumatic tires are used, do not use the wheelchair unless it has the proper tire pressure (p.s.i.). DO NOT over inflate the tires. Failure to follow these suggestions may cause the tire to explode and cause bodily harm.

4. If tires are pneumatic, recommended tire pressure is listed on the side wall of the tire.
5. The wheels and tires should be checked periodically for cracks and wear, and should be replaced when necessary at your authorized dealer or by a qualified technician.
6. For wheelchairs with handrims, periodically check to ensure they are secured to the wheels.

OPERATION AND SAFETY

REMOVABLE ARM To Swing Back & Remove Arm/Adjust Armrest Height

The armrest release lever is located on the side of the chair, on the front of the arm support tube, below the armrest pad. Unlock the arm by moving the armrest release lever in a rearward direction, approximately 1/2". The front of the armrest can then swing up and out of the engaged / locked position. The rear arm connection can now be disengaged from the skirt guard if needed.

To replace and lock armrest, first slide the rear armrest support tube into the rear slot located on the skirt guard. With the rear armrest post 'seated' into the slot, swing the front armrest support tube downward and into place over the front of the skirt guard. Lift the armrest without activating the release lever to ensure the arm is locked down.

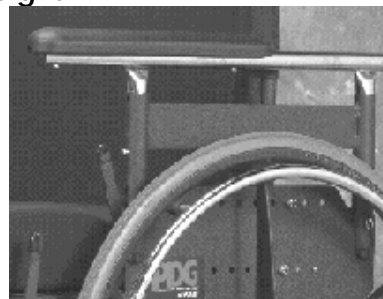

WHEEL LOCKS

Activate 'Push to Lock' wheel lock by pushing the handle forward. To adjust locks, loosen the bolt and nut which run through the mounting bracket and frame. Slide the clamp toward the rear wheel until the wheel lock shoe is embedded into tire material approximately 1/8" when handle is engaged to the lock position. Re-tighten bolt and nut to secure mounting bracket in the desired location. Inspect for correct locking action BEFORE actual use. If the lock becomes worn or damaged, replace entire assembly immediately.

CAUTION: WHEEL LOCK IS NOT A BRAKE. DO NOT attempt to stop a moving wheelchair with the wheel lock. When leaving or entering chair, ALWAYS ENGAGE BOTH WHEEL LOCKS.

WARNING: Inspect wheel Locks regularly to ensure locks are in proper adjustment as described.

ADJUSTABLE BACK FRAME

Determine appropriate seat depth under guidance of a health care professional. Adjust seat depth and back angle to correspond with desired depth and recline angle. Movable backrest receptacles are attached via four bolts installed into pre installed hole patterns. Ensure identical hole locations are used on both left and right side mounts. Your dealer may trim the Back Frame height to the desired length using a metal cutting saw or pipe cutting tool.

Push-to-Lock style



UPHOLSTERY

Back upholstery 'fit' may be adjusted by loosening or tightening hook and loop fasteners. For optimum fit, loosen fasteners, then position user in wheelchair so that upper part of upholstery supports upper back. Re-tighten fasteners securely.

Replacing/Adjusting Upholstery

PDG suggests that you study how the upholstery fastens to the chair prior to making alterations.

Periodically check upholstery for signs of ripping and sagging. If these are present, check the inner liner to determine if it has also been damaged or weakened. Replace immediately if upholstery is damaged or liner shows sagging. This will ensure uniform tautness which might not be achieved when upholstery has been used over a period of time.

WARNING: Laundering or moisture will reduce upholstery flame retardancy.

FRONT RIGGING

Attach hanger brackets to bracket receptacles on wheelchair.

1. Adjustment is made to desired length with individual sitting in wheelchair with feet on foot plates. Use wrench and hex head driver to loosen or tighten bolt on slide tube of foot plates.
2. Remove hex head bolt and tube clamp and slide footrest tube up or down until desired length is reached. Then reassemble hex head bolt into tube clamp and into threaded clamp insert. The lowest point of the foot plates should be no less than 2-1/2" from the ground or floor.

NOTE: Check to ensure that desired front rigging adjustment does not cause pressure to legs at front of seat upholstery. Such a condition could cause injury to the occupant.

WARNING:

DO NOT ATTEMPT TO STAND ON FOOT PLATES. Standing on the foot plates will cause the chair to tip forward abruptly and may result in an injurious fall to the individual.

DO NOT ATTEMPT to lift chair by the footrests or leg rests. These components are designed to separate and/or swing away from the wheelchair.

FOOT PLATES SHOULD BE in an upright position and swung out of the way when entering or exiting from the wheelchair.

REAR WHEELS

Removing/Installing the Rear Wheels/Axles

1. Push in the tip of the quick-release axle and pull the wheel off of the axle.
2. Push in the tip of the quick-release axle again and pull the axle out of the wheel hub.
3. Repeat steps 1-2 for the other rear wheel.
4. To reinstall the rear wheel onto the wheelchair, reverse steps 1-3.

WARNING: Make sure the detent pin and locking pins of the quick-release axle are fully released BEFORE operating the wheelchair. The locking pins MUST be protruding past the outside of the rear wheel axle receiver for a positive lock. Keep locking pins clean.

Adjusting the Quick Release Axle

1. Install rear wheel and quick-release axle onto the wheelchair.
2. Depress detent pin in the quick-release axle and slide axle through the wheel hub.
3. Release detent pin ensuring that the locking pins are fully released.
4. Increase or decrease end play by adjusting the locknut on the end of the quick-release axle.

WARNING: Make sure the detent pin of the quick-release axle is fully released BEFORE operating the wheelchair.

Keep locking pins clean.

Backrest Adjustment (Seat Depth / Back Recline)

Install the Backrest Assembly onto the Frame Assembly by sliding the lower end of the Back tubes into the Back Tube Receptacles located on the Frame. Note that the location of the back can be adjusted for shorter or longer seat depths and the back recline angle can be adjusted by choosing various mounting hole combinations when attaching the Back Tube Receptacle to the Frame Assembly.

Reclining Backrest Installation

A reclining backrest may be ordered with original equipment, or retrofitted onto an existing Eclipse wheelchair. When installing a reclining backrest assembly, remove the original backrest support sleeves and bolt the reclining backrest assembly in 6 locations along the skirt guard (3 bolts on each side). Note that the location of the back can be adjusted for shorter or longer seat depths. **Important!** Move the rear wheels to the most rearward axle mount position. This axle location is recommended to provide maximum stability when the back is reclined. Install extra long anti-tip tubes (supplied with the reclining backrest kit). The extra long antitip tubes provide additional protection against the wheelchair overturning when reclined. Be sure to check the wheelchair stability in full recline with the user in the wheelchair to ensure acceptable rearward stability prior to sending the user home.

Rear Axle and Anti-tip Receiver Subassembly Adjustment

Note: The rear wheel location will be factory set to the standard position unless directed otherwise via customer order. The Rear Wheel Axle location may be moved to any of four locations. To move the rear axle, use the following procedure;

The Anti-tip Receiver is bolted to the Frame via the Axle Receiver and two 7/8 OD washers which prevent the Anti-tip Subassembly from rotating. The 7/8 washers may be locked in to one of two possible locations, depending on the desired location for the rear axle.

Decide which of four Rear Axle positions is desired. When using one of the two forward axle positions, the 7/8 OD washers should be in the Anti-tip Receiver 'rearward' hole. When using one of the two rearward axle positions, the 7/8 OD washers should be in the 'forward' hole.

Assemble the 3/8-16 x 3/4" socket head screw, 3/8 ID x 7/8 OD washers (2 pcs), and 3/8 locking nut onto the Anti-tip Receivers. Do not tighten the socket head screw and nut until the washers are seated into place into an axle hole (see below).

For each Axle Receiver: Install the Axle Receiver plus the Anti-tip Receiver plus 2 washers (59/64 ID x 1-19/64 OD) plus one Receiver Nut. One of the washers should be installed between the receiver head and the 1 x 2 side tube. The other washer should be next to the nut. When the axle nut is nearly snug, use the hammer and center punch to drive the 7/8 OD washers into one of the 7/8 ID holes in the side frame. Finish tightening all screws and nuts. **DO NOT OVER TIGHTEN AXLE NUT. SNUG IS ENOUGH!**

Move Wheel Locks as required to match up with the new rear wheel location.

Upper Frame, Height and Tilt Adjustment

Note: The Frame height and seat tilt settings will be factory set to the standard position unless directed otherwise via customer order. The seat height and tilt location may be moved to any of three heights and tilts. To change seat height and tilt, use the following procedure;

To change seat height, **loosen the set screw** and then remove the 1/2" DIA bolt located under the frame which connects the Upper Frame to the Lower Frame. When the 1/2" bolt is removed, you may vary the seat height. Be sure to maintain the original arrangement for shock absorbers. There should be a 1/2" long shock absorber plus 2 washers positioned below the Lower Side Rail. There should be a 1" long shock absorber located just below the Upper Frame, where the 1/2" bolt screws into the Upper Frame.

- For a seat height of 15", use the 5" bolt plus 1" urethane sleeve with no spacer.
- For a seat height of 16", use the 6" bolt plus 1" urethane sleeve and a 1" spacer.
- For a seat height of 17", use the 7" bolt plus 1" urethane sleeve and a 2" spacer.

Use only bolts and spacers provided by PDG. The 1/2" bolt must be threaded into the Upper Frame for a length of at least 1".

Re-tighten the set screw to ensure the 1/2" bolt will not become loose during wheelchair operation.

To change seat tilt, move the 3/8-16 bolt and nut, located in the rear part of the frame, to one of three possible tilt locations as determined by the three holes in the rear of the Upper Frame Side Plate. **DO NOT OVER TIGHTEN NUTS.** 'BARELY SNUG' IS ENOUGH. (Note that it is not possible to obtain posterior seat tilt at low seat heights (14" or 15" seat height).

Wheel Lock Adjustment

Wheel locks are attached to the seat frame via two 1/4 - 20 socket head bolts. There are locking nuts located on the inside of the seat frame that can be easily accessed. To adjust the 'snugness' of wheel locks, slightly loosen the socket head bolts, slide the wheel lock assembly forward or rearward as needed, then re-tighten the socket head bolts. Test the adjustment by applying the wheel lock to ensure it can be adequately engaged

Special Note: When seat height is set at high elevations and rear wheels are located in the most rearward axle location, you may need to reverse-mount the wheel locks in order for the brake shoe to contact the tire. This can be done by reverse mounting only the part of the wheel lock that mounts to the wheelchair frame, therefore allowing the lever and shoe to be located more rearwardly.

Frame Width Adjustment

To adjust the frame width, you will need a width adjustment kit from PDG. The kit includes 6 spacers needed to establish the new width, a new width back upholstery, and a new width seat pan.

Remove the backrest from the wheelchair. Remove the old back upholstery. Knock out the 2 roll pins (located in the cross-bar) used to maintain the backrest width. Disassemble the 2 halves of the backrest. Install the new width adjustment sleeve, or remove sleeves as needed. Reassemble the two halves of the backrest tubes. With the backrest tubes held parallel to one another, drill-through the new 1/8" roll-pin holes so that you can re-install the roll-pins.

Remove the seat pan. Disassemble the lower frame by removing the 5 bolts that maintain the existing chair width. Install the new width adjustment sleeve, or remove sleeves as needed. Reassemble the two halves of the frame. Install the new seat pan.

PROCEDURE 11: MOTOR VEHICLE USE

WARNING

Identify whether your chair has been manufactured with the Transit Tie-Down System (TTDS).

If your chair is NOT equipped with the Transit Tie-Down System (TTDS), this wheelchair DOES NOT meet federal standards for motor vehicle seating.

1. **NEVER** let anyone sit in this chair while in a moving vehicle.
2. **ALWAYS** secure the rider with proper vehicle restraints. In an accident or sudden stop the rider may be thrown from the chair. Wheelchair seatbelts will not prevent this and further injury may result from the belts or straps.
3. **NEVER** transport this chair in the front seat of a vehicle. It may shift and interfere with the driver.
4. **ALWAYS** secure this chair so that it cannot roll or shift.
5. Do not use any chair that has been involved in a motor vehicle accident.

If your chair is equipped with the Transit Tie-Down System (TTDS):

1. If possible and feasible, the rider should transfer to the Original Equipment Manufacturer vehicle seat and use the vehicle restraint.
2. Use only Wheelchair Tie Down and Occupant Restraint Systems (WTORS) which meet the requirements of SAE J2249 Recommended Practice – Wheelchair Tie Down and Occupant Restraint Systems For Use in Motor Vehicles. Do not use WTORS designed to rely on the wheelchair structure to transfer occupant restraint loads to the vehicle.
3. The rider must not weigh more than 250 lbs.
4. The wheelchair has been dynamically tested in a forward –facing mode for a 30 mph frontal impact test. The wheelchair must be forward facing during transport.
5. In order to reduce the potential of injury to vehicle occupants, wheelchair-mounted accessories, such as trays and respiratory equipment should be removed and secured separately.
6. Postural supports and positioning devices should not be relied on for occupant restraint.
7. Do not alter or substitute wheelchair frame parts, components or seating.
8. The figures below show the locations of the wheelchair securement points, front and back.

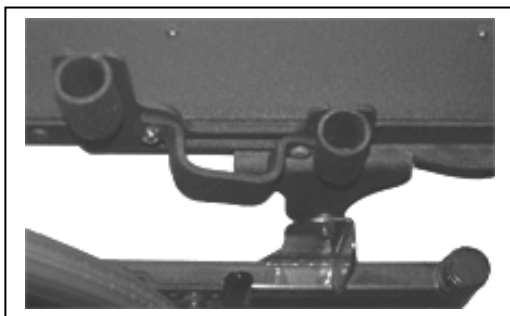

Eclipse Front Tiedown



EclipseRear Tiedown

9. Use only with Wheelchair Tie Down and Occupant Restraint Systems (WTORS) that have been installed in accordance with the manufacturer's instructions and SAE J2249.

10. Attach WTORS to securement points in accordance with the manufacturer's instructions and SAE J2249.
11. Attach occupant restraints in accordance with the manufacturer's instructions and SAE J2249.
12. Sudden stops or impacts can structurally damage your chair. Chairs involved in such incidents should be replaced.

If you fail to heed these warnings, damage to your chair, a fall, tip-overs or loss of control may occur and cause severe injury to the rider or others.

CONTACTING YOUR SUPPLIER TO OBTAIN SERVICE

PDG has trained customer service representatives in many locations. To find your nearest Customer Service Center, visit our web site at www.pdgmobility.com and click on CONTACTS. If you are uncertain about which CONTACT is most appropriate for your needs, contact PDG directly using telephone, fax, or e-mail contact information. Supply the serial number from the product you are attempting to service and we will be happy to inform you of the supplier who initially provided your product.

SPECIAL NOTE – DAMAGE REQUIRING SERVICE BY QUALIFIED SERVICE AGENT

In some circumstances it may be required that your wheelchair be returned to a Qualified Service Agent for repairs. If any of the following conditions are observed, the wheelchair must be serviced by a Qualified Service Agent;

- Any part of the frame is cracked or broken
- Any weld is cracked or broken

Always contact your Service Agent prior to sending a wheelchair for repairs. For safe and secure shipping, the wheelchair must be boxed or fastened to a pallet to ensure it does not become damaged during shipping. Service agent will provide specific instructions for packaging and shipping your wheelchair. Alternatively, Qualified Service Agent may arrange for pick-up.

PERFORMANCE ATTRIBUTES OF THE TEST WHEELCHAIR

Test Method	Test Title	Relevant Wheelchair Type	Disclosure
		Manual	All results meet at least the minimum performance requirements of AS 3695
AS 3696.1	Determination of static stability	Manual	Stable on a slope of 10° or labelled in accordance with Clause 6.1 <u>Pass</u> (100kg dummy) with locked brakes in the fore direction >15°/5° with locked brakes in the aft direction >15°/>15° with unlocked brakes in the aft direction >15°/9° with locked brakes in the transverse direction >15°/15°/
AS3696.3	Determination of the efficiency of brakes	Manual	Parking brakes hold on a slope of 10° <u>Pass</u> (100kg dummy)
AS3696.8	Static, impact & fatigue strength	Manual	<u>Pass</u> (100kg)

DIMENSIONAL ATTRIBUTES OF THE TEST WHEELCHAIR

Test Method	Test Title	Relevant Wheelchair Type	Results	
AS 3696.5	Determination of all overall dimensions, mass and turning space	Manual	Length Length without footrest Width Folded length Folded width Folded height Mass Turn around width	1100 mm 870 mm 750 mm 840 mm 750 mm 735 mm 32.3 kg 1210 mm
ISO 7176-7	Determination of seating dimensions	Manual	Seat plane angle Effective seat length Maximum seat width Seat surface height Backrest angle Backrest height	1.2° 475 mm 555 mm 437 mm 10° 500mm

LIMITED WARRANTY

This warranty is extended only to original consumer purchasers of our products. This warranty gives you specific legal rights and you may also have other legal rights, which vary from state to state or province to province.

PDG warrants the products manufactured by it to be free from defects in materials and workmanship for a period of one (1) year from date of purchase, except frame is warranted for (5) five years. If within such warranty period any such product shall be proven to the Manufacturer's satisfaction to be defective, such product shall be repaired or replaced, at PDG's option. This warranty does not include any labor or shipping charges incurred in replacement part installation or repair of any such product. PDG's sole obligation and your exclusive remedy under this warranty shall be limited to such repair and/or replacement.

For warranty service, please contact the dealer from whom you purchased your product. In the event you do not receive satisfactory warranty service, please write directly to PDG, provide dealer's name, address and date of purchase, and indicate nature of the defect. Also provide the product name and serial number. Do not return product to our factory without our prior consent.

Limitations and Exclusions: The foregoing warranty shall not apply to serial numbered products if the serial number has been removed or defaced, products subjected to negligence, accident, improper operation, maintenance or storage, commercial or institutional use or other than normal application, use or service, or to products modified without the Manufacturer's express written consent (including, but not limited to, modification through the use of unauthorized parts or attachments), or to products damaged by reason of repairs made to any component without the specific consent of PDG, or to products damaged by circumstances beyond PDG's control.

THE FOREGOING WARRANTY IS EXCLUSIVE AND IN LIEU OF ALL OTHER EXPRESS WARRANTIES. IMPLIED WARRANTIES, IF ANY, INCLUDING BUT NOT LIMITED TO THE IMPLIED WARRANTIES OF MERCHANTABILITY AND FITNESS FOR A PARTICULAR PURPOSE, SHALL NOT EXTEND BEYOND THE DURATION OF THE EXPRESS WARRANTY PROVIDED HEREIN AND THE REMEDY FOR VIOLATIONS OF ANY IMPLIED WARRANTY SHALL BE LIMITED TO REPAIR OR REPLACEMENT OF THE DEFECTIVE PRODUCT PURSUANT TO THE TERMS CONTAINED HEREIN. PDG SHALL NOT BE LIABLE FOR ANY CONSEQUENTIAL OR INCIDENTAL DAMAGES WHATSOEVER. THIS WARRANTY SHALL BE EXTENDED TO COMPLY WITH STATE/PROVINCIAL LAWS AND REQUIREMENTS.



PDG PRODUCT DESIGN GROUP INC.

Ph: (604) 323-9220 Fax: (604) 323-9097 info@pdgmobility.com www.pdgmobility.com